

RS485-ST68D

RS485 Modbus Stepper Drive



© 2017 shenzhen ECON Technology Co.,Ltd. Version 2.0

Add:2F,BuildingB,Jintai,Industrial,Park,HangchengAvenue,GushuVillage,XixiangStreet,Bao'anArea,ShenzhenCity,GuangdongProvince,China

Tel: +86 136 2096 1024

E-mail:enquiry@hybridservo.com

technical01@hybridservo.com

All rights reserved

[Please read this manual carefully before use to avoid damage the drive]



Contents

Part 1:RS485-ST68D	5
Hardware Manual.....	5
1 Descriptions	5
2 Features	5
3 Applications	5
4 Specifications	6
4.1 Electrical Specifications	6
4.2 Operating Environment	6
5 Mechanical Specifications	6
6 Connectors and Pin Assignment	7
6.1 Control signals connector	7
6.2 Encoder Feedback and hall signal Connector.....	8
6.3 Power and Motor	8
6.4 RS485 Communication Port	9
7 DIP Switch Settings	10
7.1 RS485ID Table	10
8 Hybrid servo Motors	11
8.1 Nema24 and Nema34motor	错误!未定义书签。
8.2 Nema34motor	错误!未定义书签。
9 Wiring Diagrams	12
9.1 Interface	12
9.2 Diagram.....	13
10 Protection Indications.....	13
11 Frequently Asked Questions.....	14
Problem Symptoms and Possible Causes.....	14
12 Warranty	15
Exclusions	15
Obtaining Warranty Service	15
Warranty Limitations	15
Part 2 :RS485-ST68D	16
RS485 Communication Protocol Specification.....	16
1 Network Layout.....	16
2 Communication function.....	17
2.1 Communication protocol	17
2.2 Modbus Register Address Definition(drive parameter list)	17
2.2.1 Drive Control Register.....	19
2.2.2 Drive Status Register	19
2.3 Homing Function	20
2.3.1 Return to zero point with the positive limit as zero point.....	20
2.3.2 Return to home point with the negative limit as home point.....	20
2.3.3 Exit home returning mode.....	21
2.4 General function code.....	21



2.4.1 Read And Keep Register Command 0x03	21
2.4.2 Write single Register Command 0x06.....	21
2.4.3 Write multi-Register Command 0x10.....	22
2.5 CRC Verification Example	22
2.6 Communication error code	23
2.7 How to make the motor run during a short time.....	23
Contact us:	24



This User Manual of RS485-ST68D Included:

Part 1:RS-485-ST68D hardware manual

This part for hardware, function description, parameter configuration, etc.

Part 2 :RS485-ST68D RS485communication protocol specification

This part for RS485 Modbus communication protocol.

Notice!

Read this manual carefully before any assembling and using. Incorrect handling of products in this manual can result in injury and damage to persons and machinery. Strictly adhere to the technical information regarding installation requirements.

This manual is not for use or disclosure outside of ECON technology except under permission. All rights are reserved. No part of this manual shall be reproduced, stored in retrieval form, or transmitted by any means, electronic, mechanical, photocopying, recording, or otherwise without approval from ECON technology. While every precaution has been taken in the preparation of the book, ECON technology assumes no responsibility for errors or omissions. Neither is any liability assumed for damages resulting from the use of the information contained herein.

This document is proprietary information of ECON technology that is furnished for customer use ONLY. Information in this document is subject to change without notice and does not represent a commitment on the part of ECON technology. Therefore, information contained in this manual may be updated from time-to-time due to product improvements, etc., and may not conform in every respect to former issues.

Part 1:RS485-ST68D

Hardware Manual

1 Descriptions

RS485-ST68D is our latest standard RS485 Modbus hybrid servo driver, which adopts the latest 32-bit DSP digital processing technology. The motor works with low heating ,extra smoothly, and low vibration and noise due to its advanced vector control technology .The user can set any ID address within 1-255 and any current value under the rated current to meet the applications. it can be matched with different of size motors(from Nema23-Nema34) to applied for variable applications. the drive can auto-tuning for matching the motor when power up, which can automatically generate optimal operating parameters for different motors to maximize the performance of the motor.

2 Features

- ◇ Serial Port And Auto Tune Function
- ◇ Advanced vector control technology
- ◇ Support standstill half current function
- ◇ 4 channels opto-coupler isolation OC output
- ◇ 5 channels opto-coupler isolation input,2 of them are high speed opto-coupler isolation input
- ◇ 1 channel analog output
- ◇ Communication Frequency up to 1MHz(default is 9600HZ)
- ◇ Current setting range 0.1-8A
- ◇ Smooth movement and extra low noise
- ◇ Quick response, no delay and zero settling time
- ◇ No loss of steps; no hunting; no overshooting

3 Applications

For a variety of small and medium-sized automation equipment and instruments, such as: AGV, speed pass door, engraving machine, marking machine, cutting machine, laser Phototypesetting, router machine, plotter, CNC machine tools, automatic assembly equipment. The users can get special effect from small noise, high speed equipment application.

4 Specifications

4.1 Electrical Specifications

Description	RS485-ST68D			Unit
	Min	Typical	Max	
Output Current(peak)	0.1	-	8.0	A
Input Voltage (DC)	15	36	50	VDC
Control Signal Input Current	6	10	16	mA
Control Signal Interface Electricity	4.5	5	28	Vdc
OC output Pull-Up voltage	5	-	24	Vdc
RS485 communication baud rate	1		1000-	KHz
Insulation Resistance	100			MΩ

4.2 Operating Environment

Cooling		Natural Cooling or Forced cooling
Environment	Condition	Far away from other heating device, Avoid dust, oil fog and corrosive gases, heavy humidity and strong vibration occasion, forbid flammable gases and conductive dust
	Temperature	-10℃ ~ +50℃
	Humidity	40 ~ 90%RH
	Vibration	5.9m/s ² MAX
Storage Environment		-20℃ ~ 60℃
Altitude		Less than 1000m
Weight		about 0.2KG

5 Mechanical Specifications

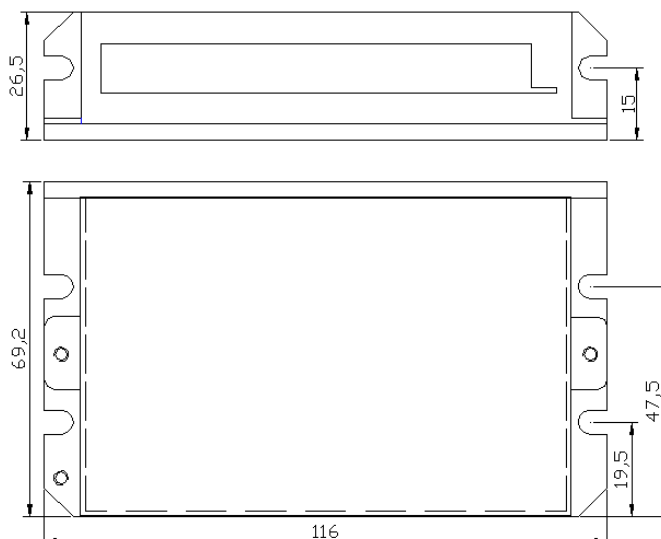

※Recommend side installation, better cooling effect, when design installation dimension, consider the terminal size and wiring!

Enhance Cooling method

- A: The driver's reliable operating temperature is usually within 60 °C, the motor operating temperature is within 80 °C;
- B: It is recommended to use the automatic half-flow mode, the current will be automatically reduced by half when the motor stops, so as to reduce the heating of the motor and the drive;
- C: When installing the driver, please use the vertical side installation, so that the cooling teeth form a strong air convection; when necessary, install a fan where is close to the drive, forced cooling to ensure that the drive is in a reliable working temperature range

6 Connectors and Pin Assignment

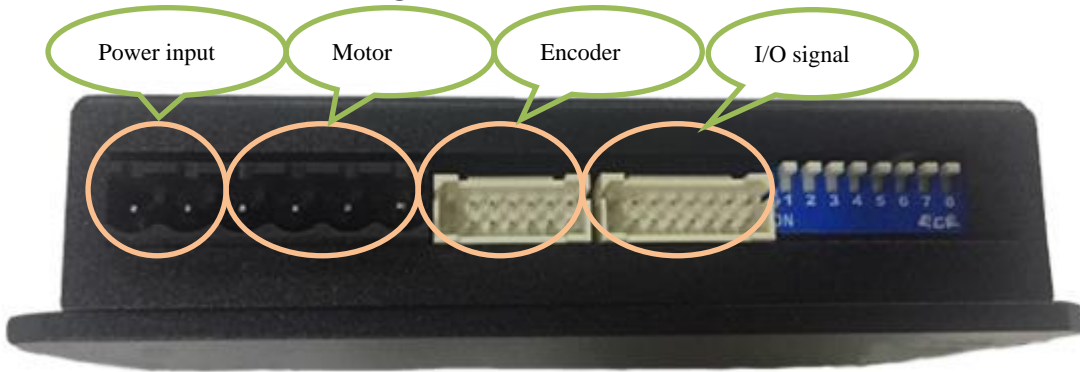

The RS485-ST68D has four connectors, connector for i/o connections, connector for Encoder Feedback and hall signal, connector for power and motor connection, and the RS485 Communication Port

6.1 Control signals connector

Pin Function	Details
pl+	INEFFECTIVE DUE TO COMMUNICATION WITH RS485
pl-	
dr+	
dr-	
in+	Low speed signal: in1, in2, in3 common positive input,5-28VDC
in1	Low speed in1 negative input
in2	Low speed in2 negative input
in3	Low speed in3 negative input
ot-	Common negative OC emitter output, ot1, ot2, ot3 ot4 OC output common terminal



ot1	ot1emitter output, the Max pull-up voltage 24Vdc, the pull-up resistance 2KΩ, the Max output current 100mA
ot2	ot2 emitter output, the Max pull-up voltage 24Vdc, the pull-up resistance 2KΩ, the Max output current 100mA
ot3	ot3 emitter output, the Max pull-up voltage 24Vdc, the pull-up resistance 2KΩ, the Max output current 100mA
Ot4	Ot4 emitter output, the Max pull-up voltage 24Vdc, the pull-up resistance 2KΩ, the Max output current 100mA
5V	5V+,current 50mA
Ain	Analog input,the input voltage is 0-5VDC
gnd	The analog input gnd

6.2 Encoder Feedback and hall signal Connector

Pin Function	Details	
ea+	Encoder channel A input	
ea-		
eb+	Encoder channel B input	
eb-		
ez+	Encoder channel Z input(if there is Z signal in encoder ,no connection needed)	
ez-		
eu+	special for dc brushless servo only, hybrid is ineffective	
eu-		
ev+		
ev-		
ew+		
ew-		
5V		Provide 5V+ dc power to motor encoder and Hall components, current 100mA
gnd		5V-

6.3 Power and Motor

Pin	Definition	I/O	Description
1	A+	O	Motor Phase A+
2	A-/U	O	Motor Phase A- (U for dc brushless servo motor)

3	B+ /V	O	Motor Phase B+ (V for dc brushless servo motor)
4	B- /W	O	Motor Phase B- (W for dc brushless servo motor)
5	+VDC	I	15-50VDC,36VDC is recommended, leaving rooms for voltage fluctuation and back-EMF.
6	GND	GND	

Power supply voltage between the provisions of the normal work, RS485 driver is best to use non-regulated DC power supply, can also use the transformer step-down + bridge rectifier + capacitor filter. However, take care that the peak value of the rectified voltage ripple does not exceed its maximum specified voltage. It is recommended that users use DC voltage lower than the maximum voltage to supply power and avoid the fluctuation of power grid beyond the working range of driver voltage.

If you are using a regulated switching power supply, be aware that the output current range of the switching power supply needs to be maximized.

Please note!

A:When wiring, pay attention to the positive and negative poles of the power supply.

B:Better use non-regulated power supply;

C:When use a non-regulated power supply, the power supply current output capacity should be greater than 60% of the drive setting current;

D:The use of regulated switching power supply, the output current of the power supply should be greater than or equal to the working current of the driver;

E:To reduce costs, two or three drives can share a power supply, but should ensure that the power supply is large enough.

6.4 RS485 Communication Port



Two RJ45 terminals

PIN	Signal	Function Description
1	RS485+	RS485+ signal

2	RS485-	RS485-signal	RS485 INPUT (RS485 IN)
3	NC	Reserved	
4	EGND	CANOPEN signal ground	
5	EGND	CANOPEN signal ground	
6	NC	Reserved	
7	EGND	CANOPEN signal ground, shield for strong interference	
8	EGND	CANOPEN signal ground	
9	RS485+	RS485+ signal	RS485 OUTPUT (RS485 OUT)
10	RS485-	RS485-signal	
11	RS232-RXD	RS232, TTL -3.3V, for protuning software using only	
12	EGND	CANOPEN signal ground	
13	EGND	CANOPEN signal ground	
14	RS232-TX	RS232, TTL -3.3V, protuning software using only	
15	EGND	CANOPEN signal ground, shield for strong interference.	
16	E5V	RS232	

Note: The cable connecting RS485-ST68D to PC must be a dedicated cable. Please check before use to avoid damage.

7 DIP Switch Settings



7.1 RS485 ID Table

ID	S1	S2	S3	S4	S5
Default	On	On	On	On	On
1	Off	On	On	On	On



2	On	Off	On	On	On
3	Off	Off	On	On	On
4	On	On	Off	On	On
5	Off	On	Off	On	On
.....
30	On	Off	Off	Off	Off
31	Off	Off	Off	Off	Off

Note: The calculation formula of the ID of RS485 is as follows: ID =: ID=1*S1+2*S2+4*S3+8*S4+16*S5. The default ID value is 0, 0 indicates the broadcast address, you can set other addresses or higher address through the master or other software.

7.2 RS485communication Baud-Rate Table

Baud Rate	SW5	SW6
8600HZ(default)	On	On
19200Hz	Off	On
38400Hz	On	Off
57600Hz	Off	Off

7.3 SW8: The terminal resistor selection for RS485.

OFF=RS485 R off(default)

ON=RS485 R on

Note: SW8 setting should be on

8 Stepper Motors

RS485-ST68D can work with the following ECON technology's ECN series stepper motors:

8.1 Nema23motor

	ECN57-10	ECN57-20	ECN57-20BK (with brake)	ECN57-25
Step Angle (Degree)	1.8	1.8	1.8	1.8
Holding Torque (N.m)	1.1	2.0	2.0	2.5
Phase Current (A)	3.0	5	5	5.0
Phase Resistance (Ohm)	0.71	0.4	0.4	0.4
Phase Inductance (mH)	2.37	1.8	1.8	1.8



Inertia (g.cm ²)	280	480	480	480
Weight (Kg)	0.72	1.2	1.8	1.0

8.2 Nema24motor

	ECN60-10	ECN60-16	ECN60-21	ECN60-31
Step Angle (Degree)	1.8	1.8	1.8	1.8
Holding Torque (N.m)	1.1	1.65	2.1	3.1
Phase Current (A)	2.8	2.8	2.8	2.8
Phase Resistance (Ohm)	0.75	0.9	1.2	1.5
Phase Inductance (mH)	2.0	3.6	4.6	6.8
Inertia (g.cm ²)	275	300	570	840
Weight (Kg)	0.6	0.77	1.2	1.4

8.3 Nema34motor

	ECN86-35	ECN86-45	ECN86-85	ECN86-120
Step Angle (Degree)	1.8	1.8	1.8	1.8
Holding Torque (N.m)	3.4	4.6	8.7	12.2
Phase Current (A)	2.8	4.2	4.2	4.2
Phase Resistance (Ohm)	1.4	0.75	0.9	1.25
Phase Inductance (mH)	3.9	3.4	6.0	8.0
Inertia (g.cm ²)	1000	1400	2700	4000
Weight (Kg)	1.7	2.3	3.8	5.4

9 Wiring Diagrams

9.1 Interface

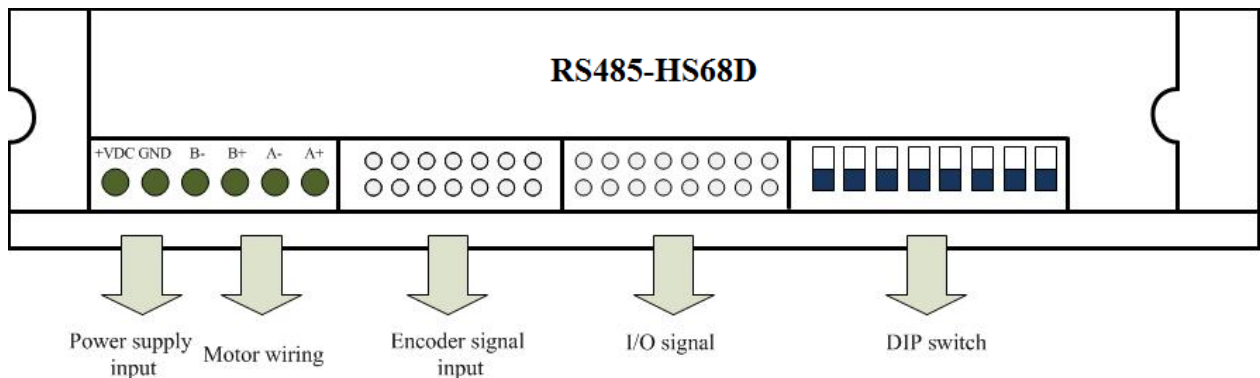

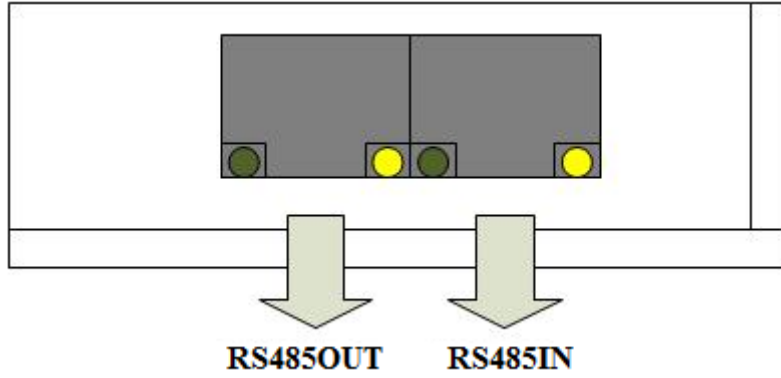

9.2 Diagram

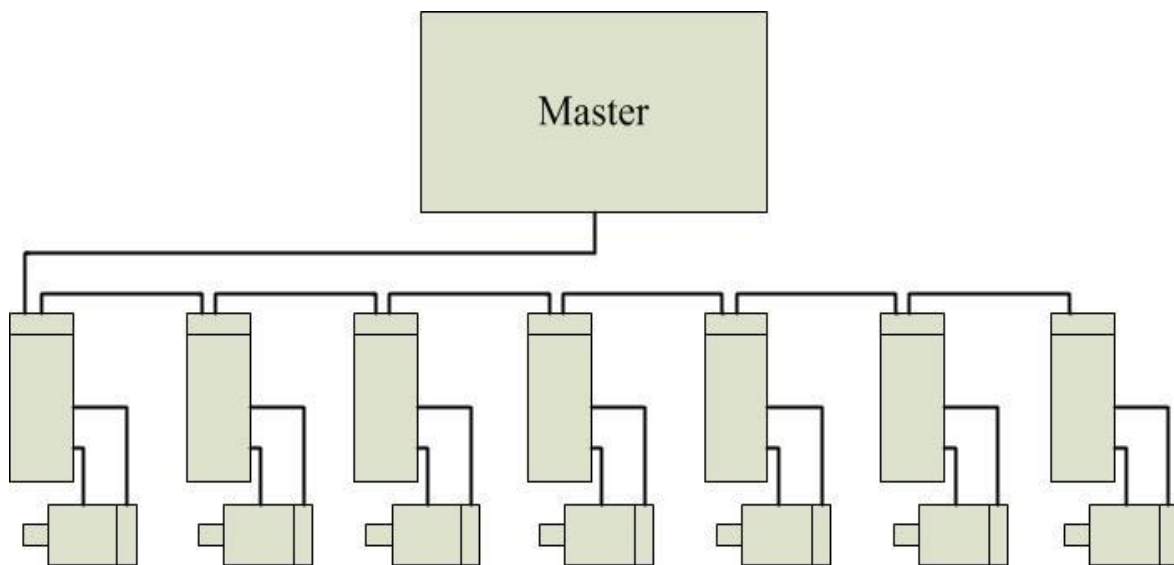

10 Protection Indications

The green indicator turns on when power-up. When drive protection is activated, the red LED blinks periodicity to indicate the error type.

Flashes Times	Red LED flash wave	Fault Description
1		over-current or phase short-circuit fault
2		over-voltage fault
3		under-voltage fault
7		position-error alarm

A:Over current or phase Short circuit protection

When a short circuit occurs or the internal drive over-current, the drive RED Led flashes 1 time, and repeat flashing within 3 seconds. At this point must discharge fault, re-power and reset.

B: Over-voltage protection



When input voltage is higher than 55V, the driver RED Led flashes twice, and flashes repeatedly within 3 seconds. At this point must discharge fault, re-power and reset.

Δ Note! Since the drive does not have the power supply reverse polarity protection function, therefore, before power on, make sure the positive and negative power supply wiring is correct. Reverse polarity will lead to burn the fuse in the drive!

11 Frequently Asked Questions

In the event that your drive doesn't operate properly, the first step is to identify whether the problem is electrical or mechanical in nature. The next step is to isolate the system component that is causing the problem. As part of this process you may have to disconnect the individual components that make up your system and verify that they operate independently. It is important to document each step in the troubleshooting process. You may need this documentation to refer back to at a later date, and these details will greatly assist our Technical Support staff in determining the problem should you need assistance.

Many of the problems that affect motion control systems can be traced to electrical noise, controller software errors, or mistake in wiring.

Problem Symptoms and Possible Causes

Problem	Possible Reason	Solution
Motor is not rotating	Power supply light is off	check power supply line, keep power supply normal
	motor shaft disabled	Pulse signal weak, increase signal current to 7-16mA
	Micro-step too small	select the suitable micro-step
	current setting is too small	Select the correct current
	drive protected	Reboot
	Enable signal too low	Pull up enable signal or disconnect
	no action to control signal	Check the power supply input
Wrong motor motion	Motor cable incorrect connect	Change any two cables of same phase(such as A+/A- change)
	Motor cable has breakage	Check and correct wiring connection
The drive In alarm	motor cable incorrect connect	Check wiring
	over-voltage or under-voltage	Check power supply
	motor or drive damaged	Replace a motor or drive
Position inaccurated	signal is interfered	Exclude interference
	Shield ground disconnect or bad connect	Reliable ground connection
	Motor cable has breakage	Check and correct wiring connection
	Wrong micro-step	Set correct micro-step



Motor stall when speed increase	Current small	Increase current
	Acceleration time is too short	Increase acceleration time
	Motor torque is too small	Select big torque motor
	Voltage is low or current is small	Suitable increase voltage and current

12 Warranty

Shenzhen ECON Technology Co., Ltd. warrants its products against defects in materials and workmanship for a period of 12 months from shipment out of factory. During the warranty period, ECON technology will either, at its option, repair or replace products which proved to be defective.

Exclusions

The above warranty does not extend to any product damaged by reasons of improper or inadequate handlings by customer, improper or inadequate customer wirings, unauthorized modification or misuse, or operation beyond the electrical specifications of the product and/or operation beyond environmental specifications for the product.

Obtaining Warranty Service

To obtain warranty service, a returned material authorization number (RMA) must be obtained from customer service at e-mail: technical01@hybridservo.com before returning product for service. Customer shall prepay shipping charges for products returned to ECON technology for warranty service, and ECON technology shall pay for return of products to customer.

Warranty Limitations

ECON technology makes no other warranty, either expressed or implied, with respect to the product. ECON technology specifically disclaims the implied warranties of merchantability and fitness for a particular purpose. Some jurisdictions do not allow limitations on how long and implied warranty lasts, so the above limitation or exclusion may not apply to you. However, any implied warranty of merchantability or fitness is limited to the 12-month duration of this written warranty.

Part 2 :RS485-ST68D

RS485 Communication Protocol Specification

1 Network Layout

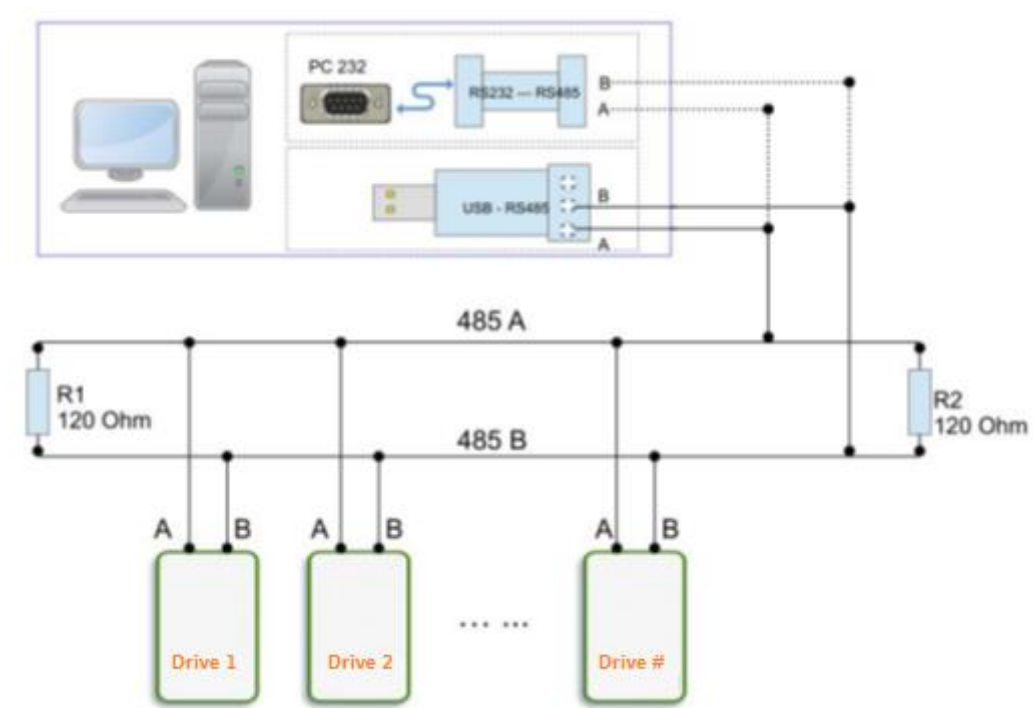

2 Communication function

Built-in ladder acceleration and deceleration curve generator, can use ladder acceleration and deceleration, through the communication command to achieve fixed-length operation, continuous operation, deceleration stop, stop immediate. Internal operation supports absolute position mode and relative position mode control, built-in common zero function, simplify development. Internal pulse generator with 32-bit speed, acceleration, travel, can achieve a wide range of trajectory.

2.1 Communication protocol

The Communication is the standard Modbus protocol, supports 0x03 (register), 0x06 (write a single register), 0x10 (16) (write multiple registers). Serial port communication format: Baud rate 9600 ~ 115200, 8 data bits, no parity verification, a stop bit.

2.2 Modbus Register Address Definition(drive parameter list)

ADD	Parameters	Property	Default value	Range	Register Description
0	Peak Current	R/W/S	5000	1~6000	Unit: MA
1	Pulse/revolution	R/W/S	6000	200~51200	Motor runs pulse per revolution
2	Standby time	R/W/S	300	100~10000	Drive in standby time,, unit: ms
3	holing current percentage	R/W/S	50	0~100	Unit: %
4	DIPs status	R			
10	Filter Time	R/W/S	4000	50~25600	Set filter time : us
15	Current loop Kp	R/W/S	1000	10~32767	When auto-tuning is enable, can be READ only; when disable it can be REWRITE
16	Current loop Ki	R/W/S	200	0~32767	When auto-tuning is enable, can be READ only; when disable it can be REWRITE
18	Baud rate selection	R/W/S	96	96~1152	96 means 9600HZ
22	Current RMS	R/W/S	3500	1~4200	Unit:MA
31	Device ID number	R			
39	Pulse amount L	R			The Receive external pulse numbers of low 16bit
40	Pulse amount H	R/W			The Received external pulse numbers of high 16bit WRITE: WRITE 1 to clear counter



48	Bus voltage	R			Feedback bus voltage ,unit 0.1V
51	Motor running direction	R/W/S	1	0/1	0: motor running direction unchanging 1: motor running direction reverse
60	homing speed	R/W/S	200	0~65535	Unit pulse/s
62	DEC/ACC low 16bit	R/W/S	3200	0~65535	Unit pulse/s^2
63	DEC/ACC high 16bit	R/W/S	0	0~65535	Unit pulse/s^2
64	Speed low 16bit	R/W/S	1600	0~65535	Unit pulse/s
65	Speed high 16bit	R/W/S	0	0~65535	Unit pulse/s
66	ACC low 16bit	R/W/S	3200	0~65535	Unit pulse/s^2
67	ACC high 16bit	R/W/S	0	0~65535	Unit pulse/s^2
68	Low stroke 16bit	R/W/S	1600	0~65535	Unit pulse
69	High stroke 16bit	R/W/S	0	0~65535	Unit pulse
70	Motion command	R/W	0	0~5	The corresponding movement is triggered, then the address changes to 6 0—decrease speed to stop 1—Positive fixed-position movement 2—Negative fixed- position movement 3—Positive continuous movement 4—Negative continuous movement 5—Immediately stop 6—Default value ,no meaning
71	Homing Command	R/W	0	0~2	0—Exit homing mode 1—homing with the positive limit as homing point 2— homing with the negative limit as homing point
72	Fixed-position movement working mode	R/W	0	0/1	0: incremental mode 1: absolute mode
73	Device control register	R/W/S			Detail definition refer to 2.2.1
74	Homing limit filter time	R/W/S	10	0~65535	1 means 50us



75	Device status register	R			Detail bit definition refer to 2.2.2
90	Save parameters	R/W	0	0/1	Read the address: Return to 0: storage is unfinished Return to 1: storage finish
91	Reset to default parameters	R/W	0	0/1	Write 1 to start clear; Read the address: Return to 0: clear is not finished Return to 1: clear is finished
92~15 0	Reversed	R			Reversed

2.2.1 Drive Control Register

Bit	Definition	Default Value	Description
7~15	Reversed	0	No
6	IO trigger movement enable (Normal default IN1 is the triggered terminal)	0	0—disable 1—enable
2~5	Reversed	0	No
1	Negative limit signal level (Normal default IN3 is the negative limit)	1	0—opto-coupler is off, then occur negative limit effective 1—opto-coupler is on, then occur negative limit effective
0	Positive limit signal level (Normal default IN2 is the positive limit)	1	0—opto-coupler is off, then occur positive limit effective 1—opto-coupler is on, then occur positive limit effective

2.2.2 Drive Status Register

Bit	Definition	Default Value	Description
8~15	Reversed	0	Reversed
7	Movement completed	1	1—internal pulse sending is completed 0—internal pulse isn't completed
6	Reversed	0	0

5	Negative limit	0	0—no negative limit signal 1—have negative limit signal
4	Positive limit	0	0—no positive limit signal 1—have positive limit signal
2~3	Reversed	0	
1	Over-voltage	0	0—No over-voltage 1—over-voltage occurred
0	Over-current	0	0—No over-current 1—over-current occurred

2.3 Homing Function

2.3.1 Return to zero point with the positive limit as zero point

The process of returning to zero after writing "1" to register address 71 (zero return command) is as follows:

Step 1: Speed and acceleration set by 62 ~ 67 register address that forward to the positive limit.

Step 2: After detect positive limit signal, deceleration stop.

Step 3: Run to the limit signal in the negative direction of the speed set by register address 60 (Back zero speed).

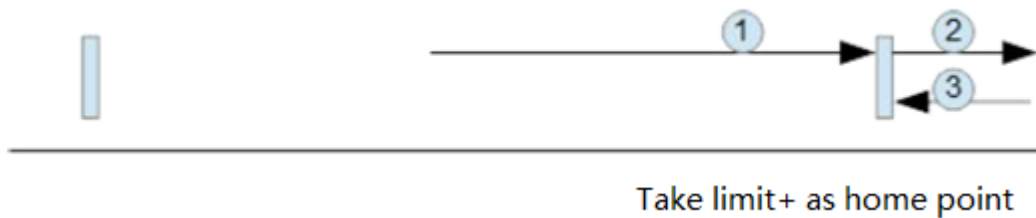

2.3.2 Return to home point with the negative limit as home point

The process of returning to zero after writing "2" to register address 71 (zero return command) is as follows:

Step 1: Speed and acceleration set by 62 ~ 67 register address that negative move to the negative limit.

Step 2: After detect negative limit signal, deceleration stop.

Step 3: Run to the limit signal in the positive direction of the speed set by register address 60 (Back zero speed).

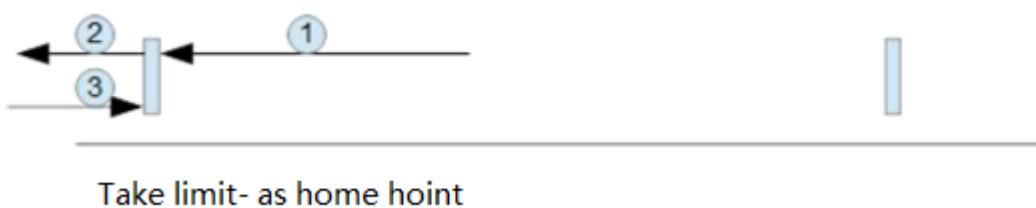



2.3.3 Exit home returning mode

After writing "0" to register address 71 (zero return command), the drive exits the zero return process and deceleration stop.

Upon completion of homing, the customer writes 1, as required (eg in absolute position mode), to register address 40, the pulse counter can be cleared.

2.4 General function code

2.4.1 Read And Keep Register Command 0x03

Master->slave device data

Device ADD	Function Code	Register ADD		Read Register Number		CRC verification	
01	03	00	00	00	01	85	0A

Slave device->master data

Device ADD	Function Code	The numbers of returned bytes	Register count		CRC verification	
01	03	02	0A	8C	BF	41

Slave device returns to current value (register address 00) 2700mA.

2.4.2 Write single Register Command 0x06

Master->Slave data

Device ADD	Function Code	Register ADD		Write data		CRC verification	
01	06	00	40	06	40	8A	4E

Slave->Master data

Device ADD	Function Code	Register ADD		Write data		CRC verification	
01	06	00	40	06	40	8A	4E



Slave speed is lower than 16bit (register address 64) write 1600pulse/s.

2.4.3 Write multi-Register Command 0x10

Master->slave data

Device ADD	Function Code	Start ADD		Write amount		Bytes		Write content		Write Content		CRC verification	
01	10	00	44	00	02	04	38	80	00	01	3B	24	

Slave->Master Data

Device ADD	Function Code	Start ADD		Write amount		CRC verification	
01	10	00	44	00	02	01	DD

The stroke to slave is lower than 16bit(register address 64)write 14464, stroke is higher than 16bit(register address 65) write 1,then total stroke is 80000pulse.

2.5 CRC Verification Example

The example take C language to calculate CRC

Uint16 Funct_CRC16(unsigned char * puchMsg, Uint16 DataLen)

```

{
  Uint16 i,j,tmp;
  Uint16 crcdata=0xFFFF;
  for(i=0;i<DataLen;i++)
  {
    crcdata=(*puchMsg)^crcdata;
    puchMsg++;
    for(j=0;j<8;j++)
    {
      tmp=crcdata&0x0001;
      crcdata=crcdata>>1;
      if(tmp){

```



```
crcredata=crcredata^0xA001;
```

```
}
```

```
}
```

```
}
```

```
return crcredata;
```

```
}
```

2.6 Communication error code

The following four situations may occur during communication:

- 1, communication is normal, the drive can normally receive and return information.
- 2, the drive due to communication error, can not normally receive the host's information, at this time the host will be in overtime processing.
- 3, the drive receive the data, but detect errors (such as CRC error, frame length error), the drive does not return information, at this time the host to do overtime.
- 4, the drive has received a normal MODBUS frame, but the drive can not handle it correctly (such as unsupported function code, unsupported register address, etc.), the driver returns the corresponding fault information, and return the fault information format: Slave address + function (0x80 + function code) + error code + CRC low + CRC high

Fault Code	Name	Description
01	Illegal function code	This drive only support function coder:0x03,0x06,0x10
02	Illegal register address	Such as the writing register address surpass the range. Beside the listed register, keep some addresses for testing, customers do not operate other registers.
03	Illegal data	Such as 03 function, the READ data exceed 100 at one time, the drive will alarm this fault. The internal drive limits the data range of some registers. Please follow the instructions.

2.7 How to make the motor run during a short time

- 1, determine the communication baud rate.
- 2, confirm the communication ID.
- 3, determine the 485 wiring sequence, so that the host can communicate with the drive successfully.
- 4, write 0x03 to parameter 70, the motor can run up.

(For example, if the ID is 1, the following message can be sent: 01 06 00 46 00 03 28 1E)



Contact us:

Shenzhen ECON Technology Co.,Ltd

***Add:2F,BuildingB,Jintai,Industrial,Park,HangchengAvenue,GushuVillage,XixiangStreet,Bao'anArea
,ShenzhenCity,GuangdongProvince,China***

Tel: +86 136 2096 1024

Sales: enquiry@hybridservo.com

Technical support: technical01@hybridservo.com